

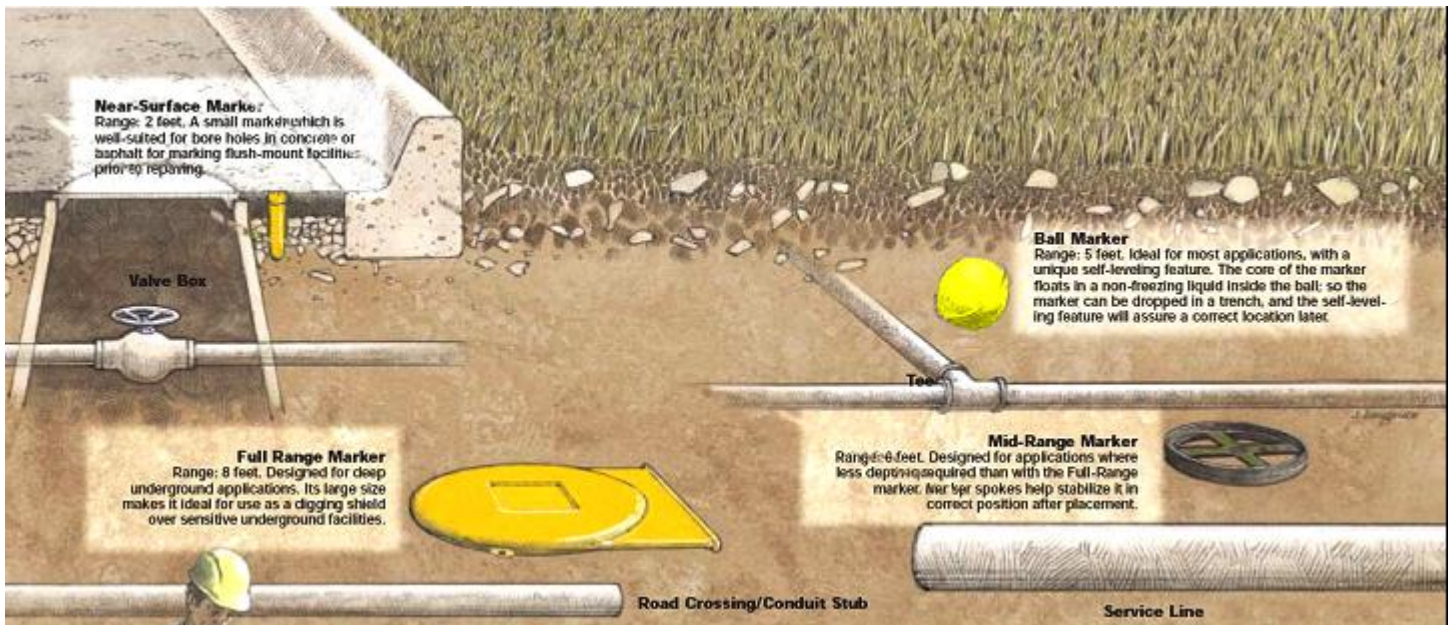

Recommendations for Marking Gas Facilities

with the Use of 3M™ EMS Electronic Markers



1.0 Overview

The 3M™ electronic marker system is intended to make the job of precisely locating underground facilities easier and faster. The basic component of the system is a durable electronic marker buried above key underground elements in the process of their construction or maintenance. A stand-alone 3M™ Dynatel™ marker locator model 1420, an integrated 3M™ Dynatel cable/marker locator 2200M-ID series or a 3M™ Dynatel™ cable locator 2200 series combined with a 3M™ Dynatel™ EMS Accessory 2205/2206 provides fast and accurate location of a marker many years after its placement.

Depending on the resonant frequency and the color, electronic markers are used to mark a wide range of underground facilities such as oil and gas pipelines, water supply pipelines, wastewater pipelines, telecommunication lines, power supply lines, cable television networks, and so on.

The solid yellow marker is used for oil and gas applications. These are tuned to 169.8 kHz and are available in 4 different form factors for varying applications.

Gas markers consist of a sealed shell containing a passive antenna – a low-frequency resonance circuit tuned to the 83.0 kHz frequency. The locator sends a signal to the passive marker that energizes it, this signal is reflected back to the locator. Electronic markers are immune to congestion and extremely reliable. Electronic markers are typically installed during construction when the facility is visible to the eye, making it one of the most trusted methods for positive identification of buried facilities.

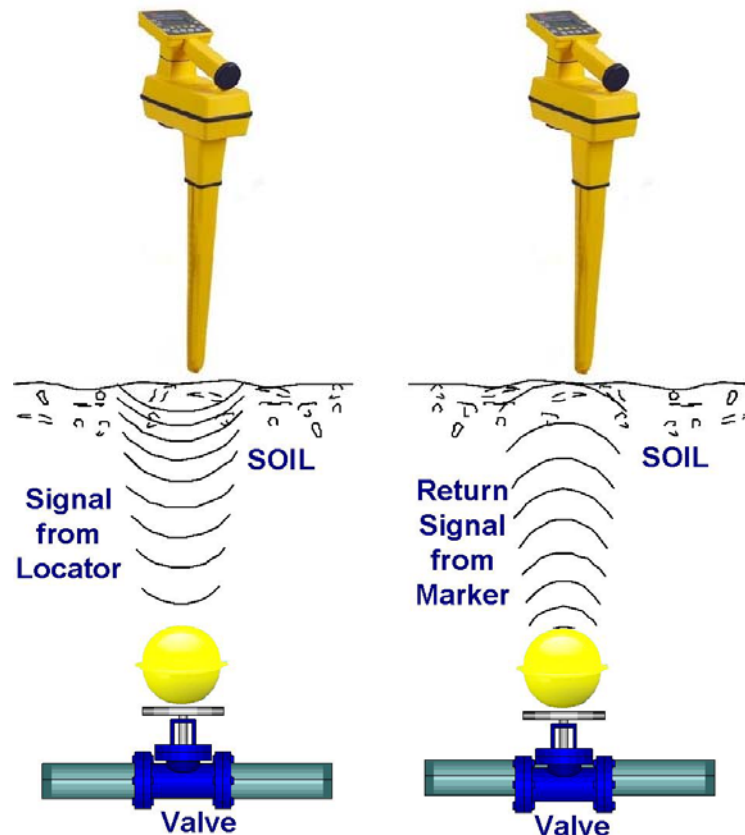

2.0 General Recommendations for Electronic Marker placement

2.1 Recommended placement

- All 'Items of Plant' that are assigned unique reference numbers on facility maps and records.
- Valve boxes
- Valves of all types
- Buried transformers
- Repair points
- Squeeze points
- Service stubs
- Depth changes
- Laterals
- Interface points for corrosion protection systems
- Bends - changes of direction, arcs
- Depth changes - lateral deflection
- Encasement ends - conduit ends of horizontally directional drilled facilities
- Manhole covers, manhole corners
- Water crossings
- Major road crossings
- Rail crossings
- Utility crossings – locations where the pipeline crosses over or under other utilities.
- Contractors shall certify in writing that electronic markers are in place, prior to paving over any of the above locations. Electronic markers that are found to be missing shall be installed at the contractor's expense.
- Using the GPS interface on the 3M™ Dynatel™ Locator model 1420 and 2200M-ID series will also provide positive verification of marker placement during construction and direct data import capability to leading industry standard GIS systems for electronic map updating.

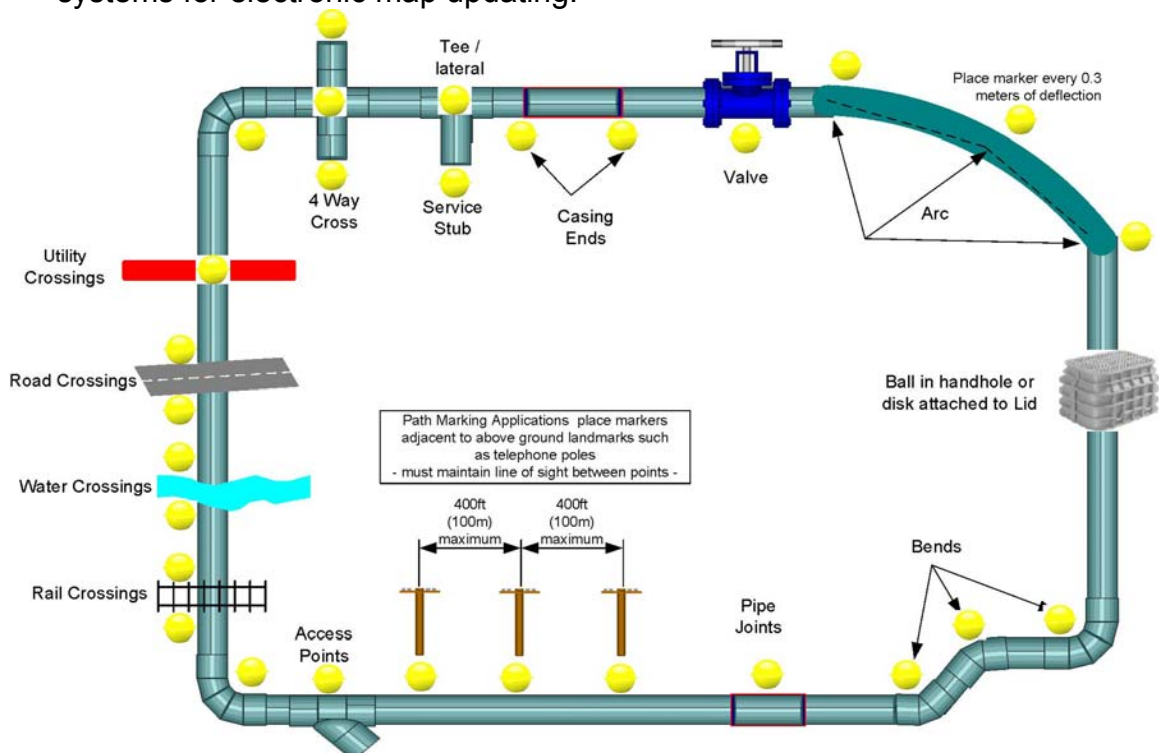

3.0 Recommended Marker Spacing and Depth

3.1 Recommended Depth for Ball Markers

- Maximum distance from ground surface to marker is 3M™ Ball Marker model 1425-XR/ID
 - 4ft. (1.2 m) read range using CE approved version of 3M marker locator
 - 5ft (1.5m) read range using US version of 3M marker locator
- 3M™ Ball Marker model 1405-XR
 - Maximum installation depth – 5ft. (1.5m) detection range
- To increase detection area on surface, it is recommended to place the marker at half if it's rated depth. This will produce a detection area of approximately 6ft. (2 meters) in diameter.
- If fill to finish grade is anticipated, place marker at a 2ft. (0.5m) depth, this may vary depending on the amount of fill required.
- If a cut to finish grade is anticipated, place marker at its maximum rated distance of 4ft. (1.2m) for CE models and 5ft. (1.5m) for US models.
- If it is anticipated that there will be a need to reprogram the ID marker after it has been buried, place marker at a maximum depth of 1ft. (0.3m).

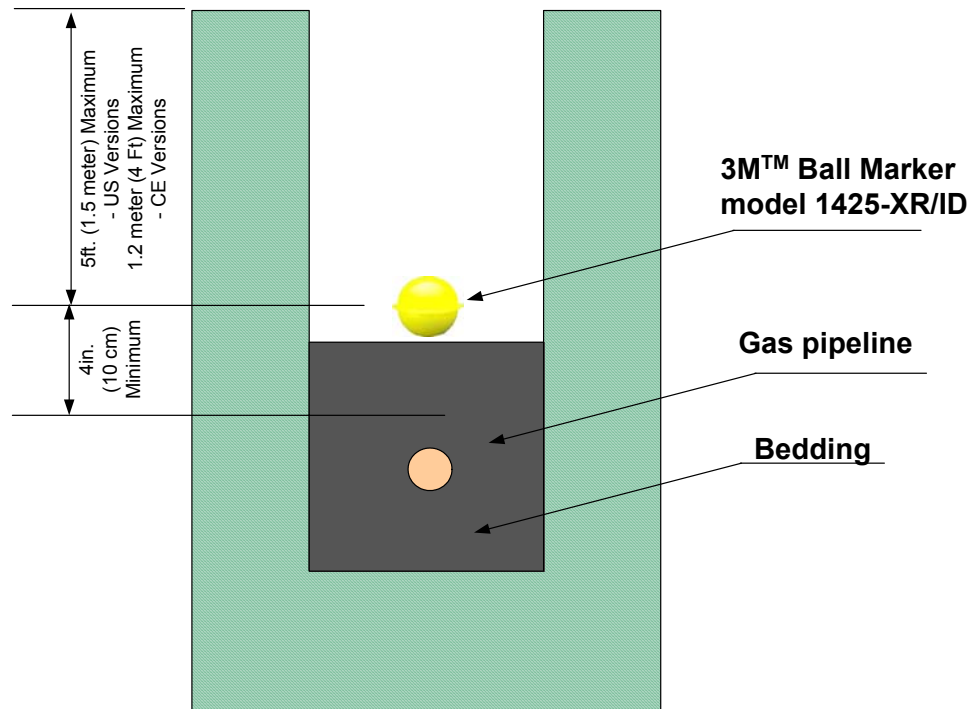

3.2 Spacing to Utility

Place ball marker at a distance of at least 4in. (10cm) from the facility.

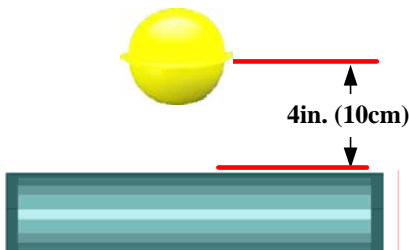

3.3 Spacing Between Markers

- Minimum distance between markers should be at least 6ft (2m) for clear identification
- In straight sections for path marking applications, it is recommended to place markers adjacent to existing above ground landmarks such as telephone or power poles to simplify future locating. Markers should be placed where there is direct line of sight to the next marker. Recommended 400ft. (100m) maximum distance between markers with a preferred distance of 200ft. (50m) between markers.
- In bends or lateral deflections, it is recommended to place one marker for every 1ft. (0.3m) deflection (arc) to accurately indicate pipeline position.

4.0 Standard Tie Down Procedure

1. Before placing the ball marker over the key point, decide if a tie down procedure is necessary to keep it in place. If so, secure the marker by inserting a cable tie through one or both tie-down tabs and to the key point.
2. If the key point is metallic, we recommend that the ball marker be separated from it with a minimum of 4in. (10cm.) of clean fill dirt.
3. Hand fill at least 6in. (15cm) of soil over the marker.
4. Backfill the hole.

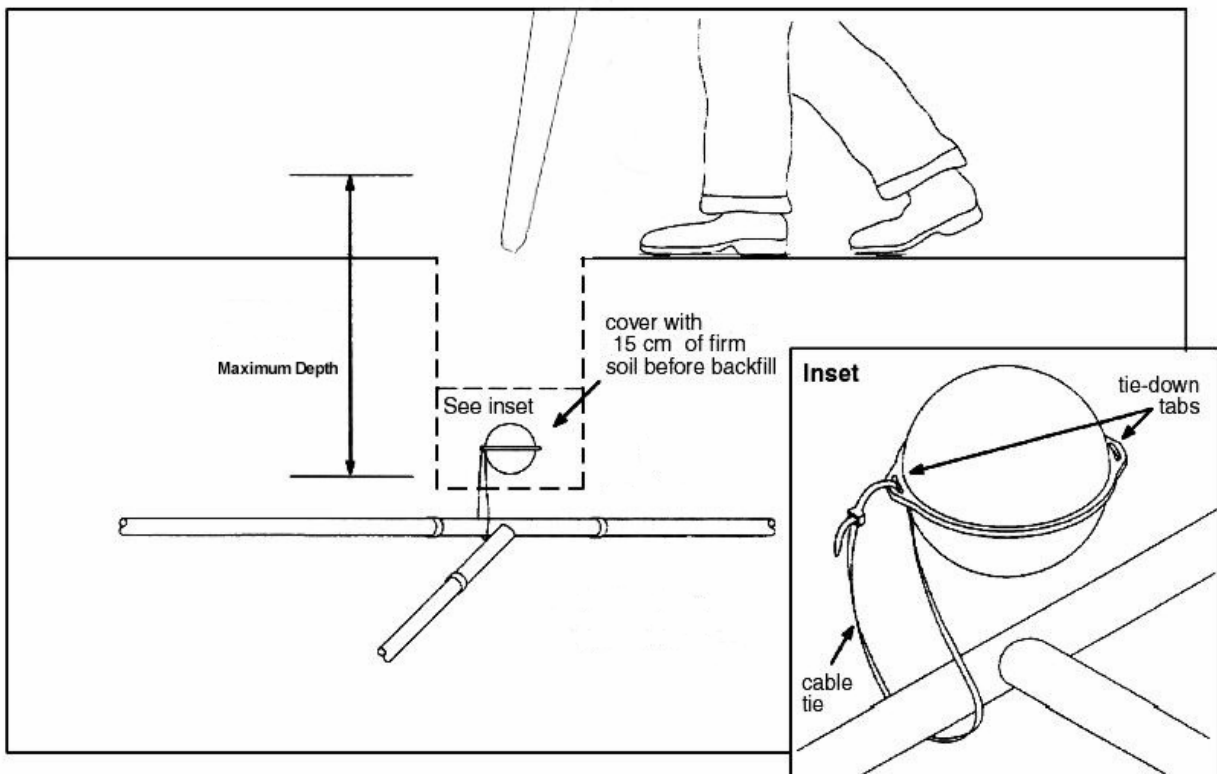

4.1 Alternate Tie Down Procedure – For deeper facilities

Tie to steel rebar

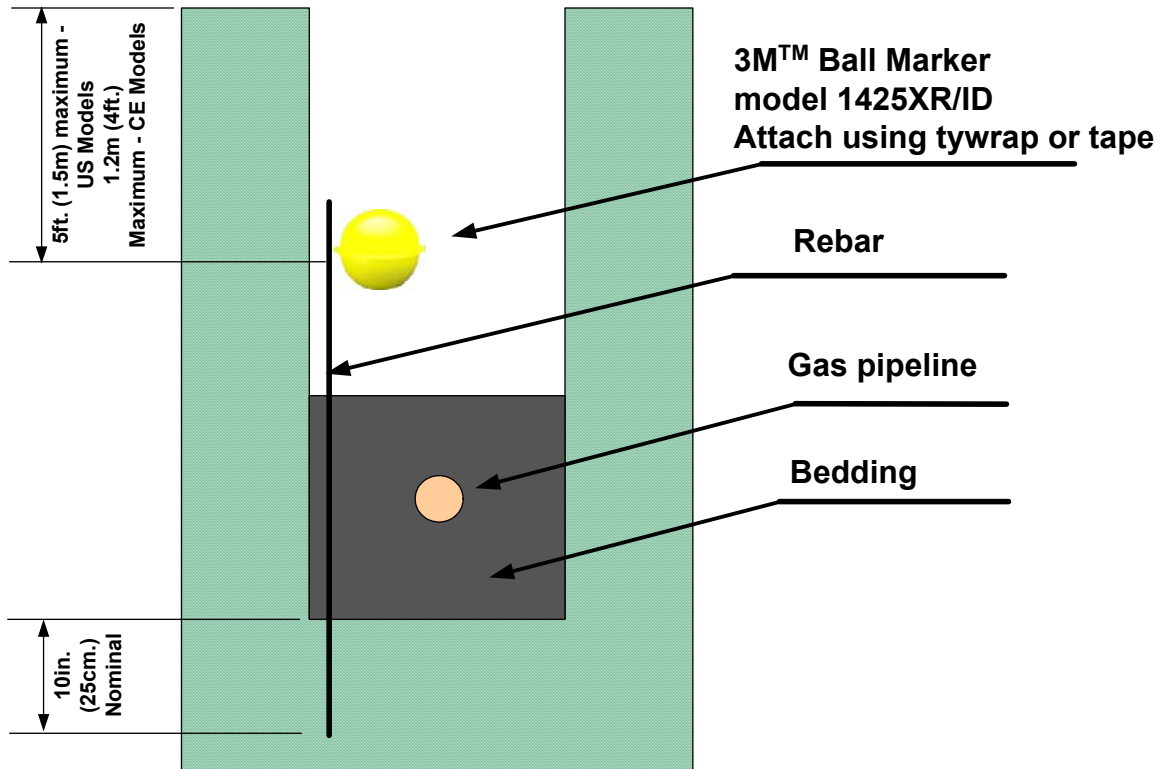

5.0 Additional Placement Recommendations for 3M™ Ball Marker 1425-XR/ID

Additional applications are possible with the XR/ID series of Ball Markers due to their ability to store specific facility information. Known applications for ID ball markers in gas applications are shown below.

Ball Markers mark the following points	Facility information that may be of value to program into the ID Ball Marker
<ul style="list-style-type: none"> • All 'Items of Plant' that are assigned unique reference numbers on facility maps and records. • Valve boxes • Valves of all types • Fittings and couplings of all types • Excess flow valves • Repair points • Squeeze points • Service stubs • Service taps • Depth changes • Laterals, tee's, crosses, branches • Bends - changes of direction, arcs • Interface points for corrosion protection systems • Depth changes – lateral deflection • Encasement ends - conduit ends of horizontally directional drilled facilities • Manhole covers, manhole corners • Water crossings • Major road crossings • Rail crossings • Utility crossings – locations where the pipeline crosses over or under other utilities. • Contractors shall certify in writing that electronic markers are in place, prior to paving over any of the above locations. electronic markers that are found to be missing shall be installed at the contractor's expense. • Using the GPS interface on the 3M™ Dynatel™ locator models 1420 and 2200M-ID can simplify mapping and provide additional guidance to field personnel for positive verification of marker placement. 	<ul style="list-style-type: none"> • Utility type (Gas) • Description of facility point (see left column) • Item of plant identification number (IPID) • Degree of bend <ul style="list-style-type: none"> ○ 11.25 ○ 22.5 ○ 45 ○ 90 • Depth (to facility, or from marker to facility) • Size of pipe • Type of material of pipe <ul style="list-style-type: none"> ○ HDPE ○ MDPE ○ PVC ○ PEX ○ ABS ○ PAC ○ PA-11 ○ PA-12 ○ Steel ○ Cast Iron ○ Ductile Iron • Direction • Distance or length • Date of installation or repair

6.0 Types of 3M™ EMS Electronic Markers for gas applications

3M offers a complete line of electronic markers that provide solutions supporting a variety of gas applications.

6.1 3M™ Ball Marker model 1405-XR

The patented self leveling design of 3M™ ball marker model 1405-XR aligns the marker coil inside the ball in a horizontal position regardless of how they are placed in the ground..The marker shell is made from a high-strength plastic, which protects the device from mechanical and weather damage. The marker contains an antenna molded inside a water-resistant plastic disc, which is free-floating on the surface of a nonfreezing liquid. 1405-XR ball markers are used in to mark points of special interest that may need to be accessed in the future. In gas applications where there is a need to mark non metallic pipelines, the 1405-XR ball marker can be used for path marking as a long life alternative to tracer wires or tapes.



- Shell diameter – 4in. (10cm)
- Maximum installation depth – 5ft. (1.5m) detection range
- Minimum distance from the facility– 4in.(10cm) from the ball center

6.2 3M™ Ball Marker model 1425-XR/ID

This marker is similar to the 1405-XR ball marker in size and form. Additionally, the 1425-XR/ID ball marker contains an RFID microchip, which allows introduction and storage of facility data. Each marker comes pre-programmed with a unique 10 digit identification number. This pre-programmed number is also attached to the marker on a removable bar-coded tag, which can be peeled off before installation and attached to facility maps. Please reference **section 5.0** of this document for a comprehensive listing of known applications for this marker in oil and gas applications. In general terms, 1425-XR/iD ball markers are ideal for marking underground facilities in urban areas with a high density of underground utilities, in rural areas where there are few physical landmarks that can be referenced in maps, and for marking facilities that can not be located or are difficult to accurately locate using traditional electromagnetic cable locating techniques. Additionally, 1425-XR/ID ball markers are ideal for marking high value facilities or lifeline facilities where service outages would have significant impact, hazard, cost or hardship.

- Shell diameter – 4in. (10cm)
- Maximum installation depth:
 - 1.2 m (4ft.) read range using CE approved version of 3M marker locator
 - 5ft (1.5m) read range using US version of 3M marker locator
- Minimum distance from the facility– 4in. (10 cm) from the ball center

6.21 Spacing of ball markers to buried facility

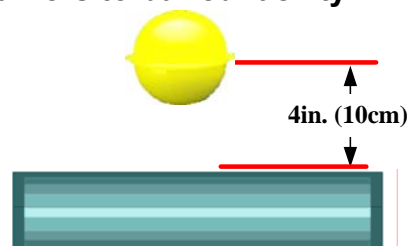

6.3 3M™ Disk Marker model 1412-XR

Model 1415-XR disk markers are used in hand hole applications where they are attached mechanically to the top cover the box. 1415-XR disk markers are identical in performance to the 1405-XR ball marker. 1415-XR disk markers are not intended for direct bury applications or applications where they would be attached to solid metal manhole covers.

- Shell diameter – 4in. (100mm)
- Marker height – 0.7in (1.8cm)
- Maximum installation depth – 5ft. (1.5m) detection range

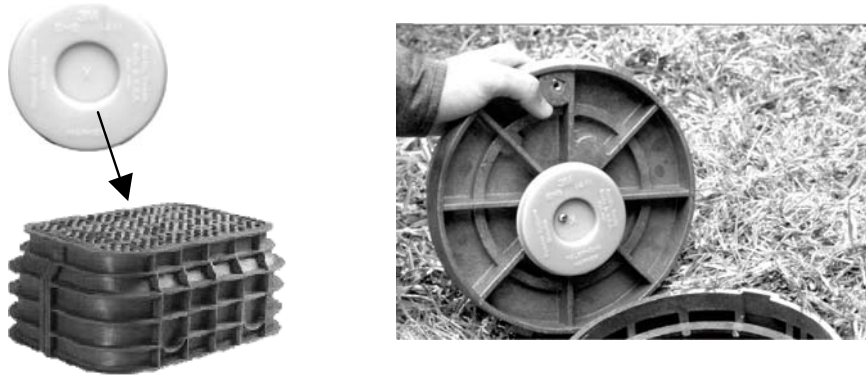

6.4 3M™ Near Surface Marker model 1436

Recommended for urban applications, near-surface markers allow for convenient marking facilities of under asphalt or concrete or for marking facilities after construction has completed. The marker is installed vertically at a small depth in a hole drilled or gouged in soil or in street pavement. Near surface markers are also ideal for path of facilities installed using trenchless (HDD) technology. In recent years, near surface markers have become increasingly popular for marking existing or legacy facilities due to their ease of installation.

- Case diameter – 0.8in (20mm)
- Case length - 3in. (76mm)
- Maximum installation depth – 2ft. (0.6m)
- Minimum vertical distance from facility – 2in. (5cm)
- Minimum horizontal distance from facility – 1in. (2.5cm)
- **6.41 Spacing of near surface marker to buried facility**

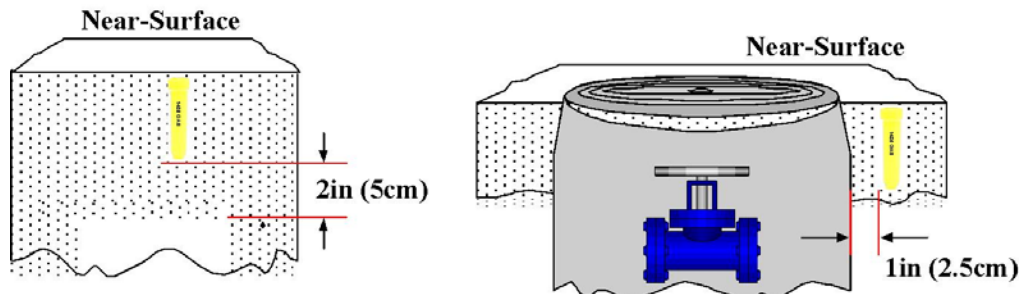

6.5 3M™ Mid Range Marker model 1259

Model 1259 mid range markers are used in areas with low-density underground facilities as point markers for items of special interest such as joints, fittings, repair points, service stubs and as guides for marking linear segments of the paths of pipelines that are deeper than be accommodated with the 3M 1400 series ball markers. The 1259 mid range marker is often used in larger 'point' excavations but not typically used in narrow trench applications due to its' larger diameter.

- Case diameter – 8.4in. (210mm)
- Case height – 1.2in. (30 mm)
- Maximum installationdepth - up to 6ft. (1.8m)
- Minimum distance from the facility to marker - 4in. (10cm)



6.51 Spacing of mid range marker to buried facility

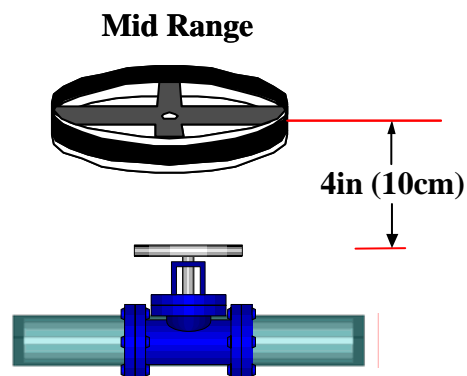

6.6 3M™ Full Range Marker model 1254

The full range marker is designed for marking deep underground facilities. Its' large diameter is also valued by facility owners as a 'dig shield' that can protect the facility from damage from being cut or damaged by a shovel during excavation. When placed above the facility, the full range marker also serves as a dig shield or cover, which warns of encroachment to the underground facility.

- Case diameter – 15in.(380mm)
- Case thickness – 0.7in.(17mm)
- Maximum placement depth – up to 8ft. (2.4m)
- Minimum distance from the facility marked – 6in.(15cm)



6.61 Spacing of full range marker to buried facility

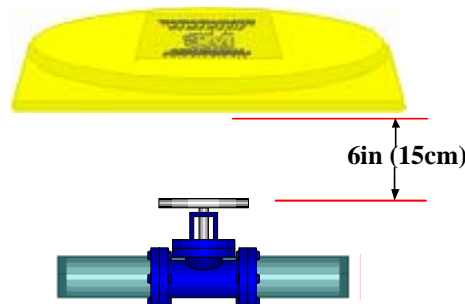

7.0 3M™ Dynatel™ Electronic Marker Locators

3M™ Dynatel™ Marker Locators are recommended for locating 3M™ Electronic Marker System markers. 3M offers stand-alone EMS locators – Models 1420 (US) and 1420E (CE approved for export). Additionally 3M offers integrated pipe locators with EMS locating capabilities, the 2200M-ID series. The 3M™ Dynatel™ 2200M-ID series locators provide a single integrated platform for what has previously been two separate test sets. This can reduce the initial capital expenditure, the number of pieces of equipment that need to be maintained, space requirements in the vehicle and number of test sets that have to be carried by a technician into the field to perform a locate. 3M has recently introduced an interface for these units to communicate with selected GPS receivers which can improve efficiencies in documenting as-built facilities and reduce the need for inspection.

3M™ Dynatel™ offers the following electronic marker and multi-purpose locators.



Model 1420/1420E



Model 2250M/2250M-ID



Model 2273M/2273M-ID



With GPS interface

Additional information about 3M™ Dynatel™ pipe and electronic marker locating products for gas applications is available at <http://www.3m.com/dynatel> or contact your local 3M sales professional.

Important Notice

All statements, technical information, and recommendations related to 3M's products are based on information believed to be reliable, but the accuracy or completeness is not guaranteed. Before using this product, you must evaluate it and determine if it is suitable for your intended application. You assume all risks and liability associated with such use. Any statements related to the product which are not contained in 3M's current publications, or any contrary statements contained on your purchase order shall have no force or effect unless expressly agreed upon, in writing, by an authorized officer of 3M.

Limited Product Warranty

All 3M CMD products, test and measurement instruments (except accessories), manufacture dated test leads, and rechargeable batteries will conform to 3M's published specifications and will be free from defects in material and manufacture for a period of twelve (12) months from the date of purchase. Dry cell batteries included in any of 3M's products are warranted only to the extent the battery manufacturer determines such batteries are covered by its warranty. Accessories for test and measurement instruments are warranted for ninety (90) days after purchase. 3M's

obligations and liability under this warranty are limited to repairing, replacing or refund of the purchase price, at 3M's option, any of 3M's products which, after normal and proper usage, are determined by 3M to be defective. This warranty does not extend to any of 3M's products which have been subjected to misuse, neglect, accident or improper applications, nor shall it extend to products which have been repaired or substantially altered outside 3M's manufacturing or repair facility, nor to any associated instruments, equipment or apparatus. Before utilizing

any of 3M's products, BUYER should determine the suitability of the product for BUYER'S intended use. **3M MAKES NO OTHER WARRANTIES, EXPRESSED OR IMPLIED, INCLUDING ANY IMPLIED WARRANTIES OF MERCHANTABILITY OR FITNESS FOR A PARTICULAR PURPOSE.** In no case, shall 3M be liable for any special, incidental, or consequential damages based upon breach of warranty, breach of contract, negligence, strict liability or any other legal theory. This limitation does not apply to claims for personal injury.

Special Condition: Shipments into authorized distributor locations will have an additional ninety (90) day warranty period.

Conditional Lifetime Warranty

In addition to the Limited Product warranty stated above, 3M provides the following Conditional Lifetime Warranty for its Electronic Marker Products: When installed in accordance with 3M's installation instructions, 3M warrants Electronic Markers for the lifetime of the product, to be free from defects in material and manufacture, provided the Electronic Markers are located with 3M Dynatel™ Test and Measurement Instruments or other brand locators as may be designated by 3M in writing. This warranty does not extend to Electronic Markers that have been subjected to misuse or improper applications or that have been repaired or altered by others. **3M MAKES NO OTHER WARRANTIES INCLUDING, BUT NOT LIMITED TO, ANY IMPLIED WARRANTY OF MERCHANTABILITY OR FITNESS FOR A PARTICULAR PURPOSE.** If the Marker is found to be defective within the product's normal lifetime, your exclusive remedy shall be, at 3M's option, to repair or replace the Marker or refund the purchase price.